

PAPER TRAY UNIT
(Machine Code: A860/B390)

1. OVERALL MACHINE INFORMATION

1.1 SPECIFICATIONS

Paper Size:	A5 to A3 HLT lengthwise to DLT
Paper Weight:	60 ~ 105 g/m ² , 16 ~ 28 lbs.
Tray Capacity:	500 sheets (80 g/m ² , 20 lbs.) x 2 trays
Paper Feed System:	Feed roller and friction pad
Paper Height Detection:	4 steps (100%, 70%, 30%, Near end)
Power Source:	24 VDC, 5 VDC (from the copier/printer) 120 Vac: 120 V version, from the copier/printer when the optional tray heater is installed 220 ~ 240 Vac: 230 V version, from the copier/printer when the optional tray heater is installed
Power Consumption:	Max: 30 W (Copying/printing) 23 W (Optional Tray Heater On) Average: 17 W (Copying/printing) 15 W (Optional Tray Heater On)
Weight:	25 kg (55 lbs)
Size (W x D x H):	550 mm x 520 mm x 271 mm

1.2 MECHANICAL COMPONENT LAYOUT

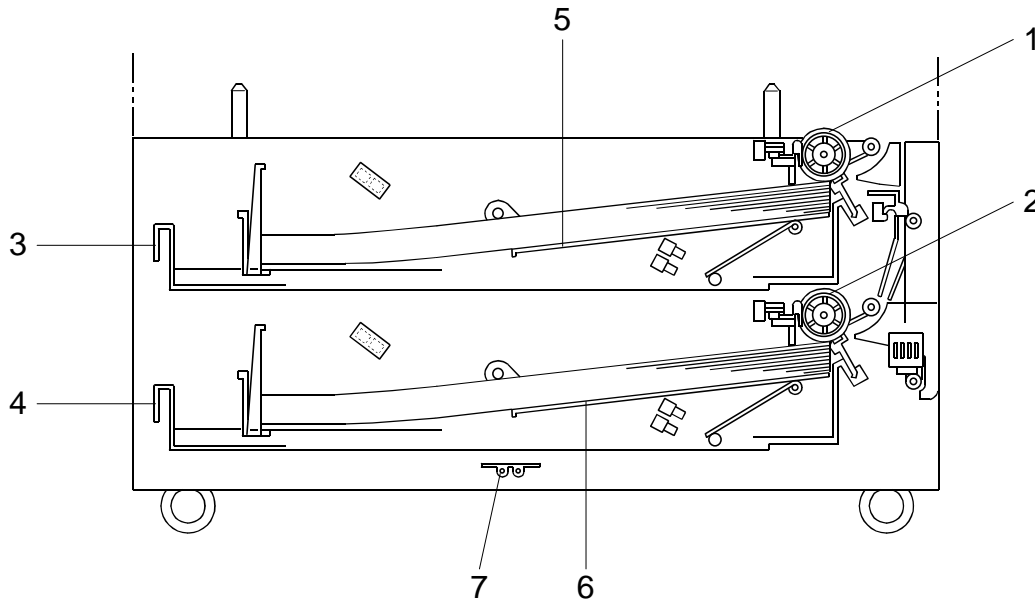

B390V101.WMF

- | | |
|----------------------------|-------------------------|
| 1. Upper paper feed roller | 5. Upper bottom plate |
| 2. Lower paper feed roller | 6. Lower bottom plate |
| 3. Upper tray | 7. Optional tray heater |
| 4. Lower tray | |

1.3 ELECTRICAL COMPONENT LAYOUT

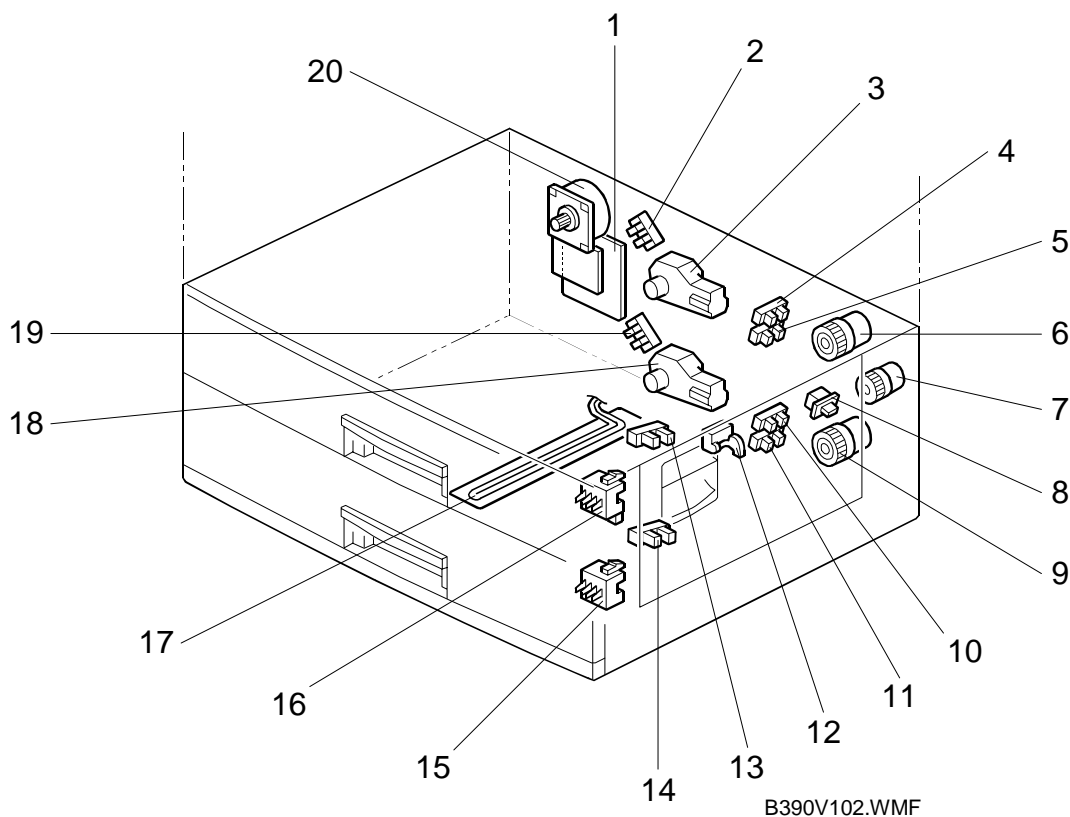

- | | |
|---------------------------------|---------------------------------|
| 1. Tray main board | 11. Lower paper height 1 sensor |
| 2. Upper lift sensor | 12. Vertical transport sensor |
| 3. Upper lift motor | 13. Upper paper end sensor |
| 4. Upper paper height 2 sensor | 14. Lower paper end sensor |
| 5. Upper paper height 1 sensor | 15. Lower paper size switch |
| 6. Upper paper feed clutch | 16. Upper paper size switch |
| 7. Relay clutch | 17. Optional tray heater |
| 8. Tray cover switch | 18. Lower lift motor |
| 9. Lower paper feed clutch | 19. Lower lift sensor |
| 10. Lower paper height 2 sensor | 20. Tray motor |

Options

1.4 ELECTRICAL COMPONENT DESCRIPTION

Symbol	Name	Function	Index No.
Motors			
M1	Tray	Drives all rollers.	20
M2	Upper Lift	Lifts the upper tray bottom plate.	3
M3	Lower Lift	Lifts the lower tray bottom plate.	18
Sensors			
S1	Upper Lift	Detects when the paper in the upper tray is at the correct feed height.	2
S2	Lower Lift	Detects when the paper in the lower tray is at the correct feed height.	19
S3	Upper Paper End	Informs the copier/printer when the upper tray runs out of paper.	13
S4	Lower Paper End	Informs the copier/printer when the lower tray runs out of paper.	14
S5	Vertical Transport	Detects misfeeds.	12
S6	Upper Paper Height 1	Detects the amount of paper in the upper tray.	5
S7	Upper Paper Height 2	Detects the amount of paper in the upper tray.	4
S8	Lower Paper Height 1	Detects the amount of paper in the lower tray.	11
S9	Lower Paper Height 2	Detects the amount of paper in the lower tray.	10
Switches			
SW1	Tray Cover	Detects whether the tray cover is opened or not.	8
SW2	Upper Paper Size	Determines what paper size is in the upper tray.	15
SW3	Lower Paper Size	Determines what paper size is in the lower tray.	16
Magnetic Clutches			
MC1	Upper Paper Feed	Starts paper feed from the upper tray.	6
MC2	Lower Paper Feed	Starts paper feed from the lower tray.	9
MC3	Relay	Drives the relay rollers.	7
PCBs			
PCB1	Tray Main	Controls the paper tray unit and communicates with the copier/printer.	1
Others			
H1	Optional Tray Heater	Removes humidity from the paper in the trays.	17

1.5 DRIVE LAYOUT

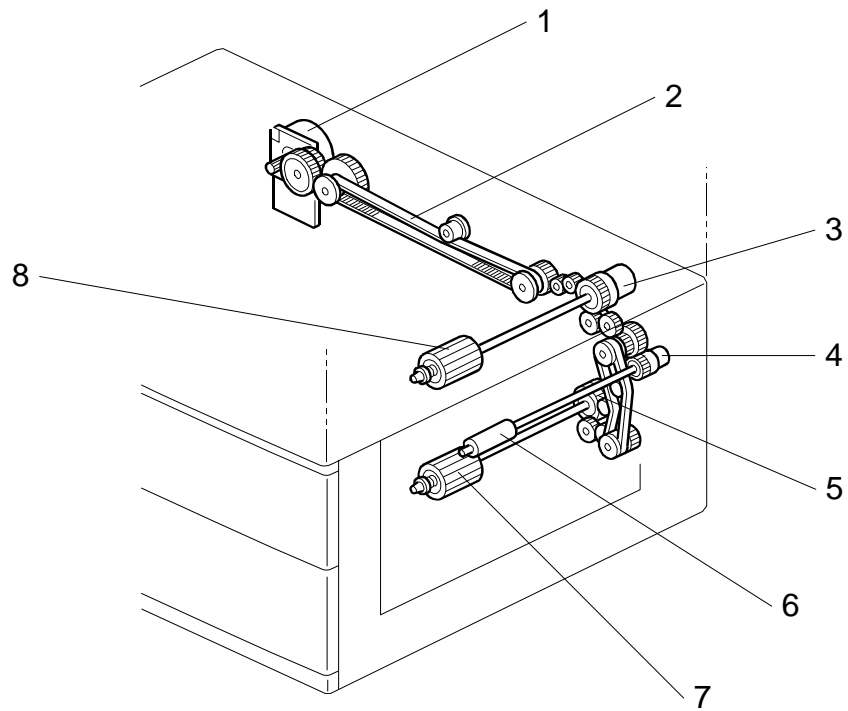

B390V103.WMF

- | | |
|----------------------------|----------------------------|
| 1. Tray motor | 5. Lower paper feed clutch |
| 2. Drive belt | 6. Relay roller |
| 3. Upper paper feed clutch | 7. Lower paper feed roller |
| 4. Relay clutch | 8. Upper paper feed roller |

2. DETAILED DESCRIPTIONS

2.1 PAPER FEED AND SEPARATION MECHANISM

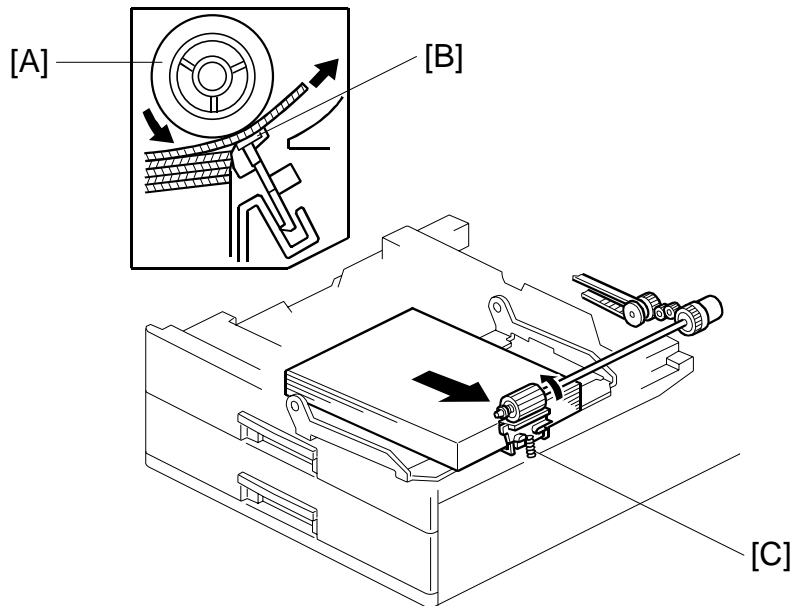

B390D104.WMF

The paper tray holds 500 sheets. The paper feed roller [A] drives the top sheet of paper from the paper tray to the copier/printer. The friction pad [B] allows only one sheet to feed at a time. The friction pad applies pressure to the feed roller with a spring [C].

2.2 PAPER LIFT MECHANISM

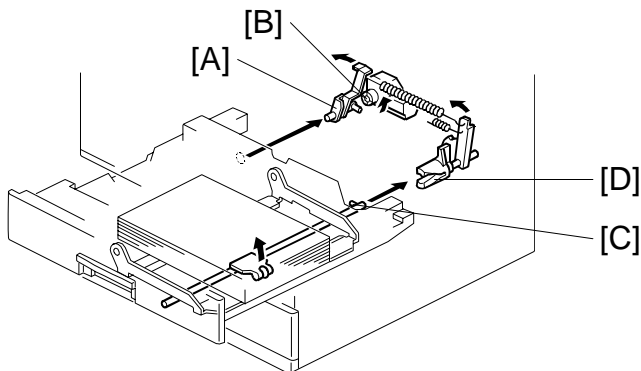

B390D106.WMF

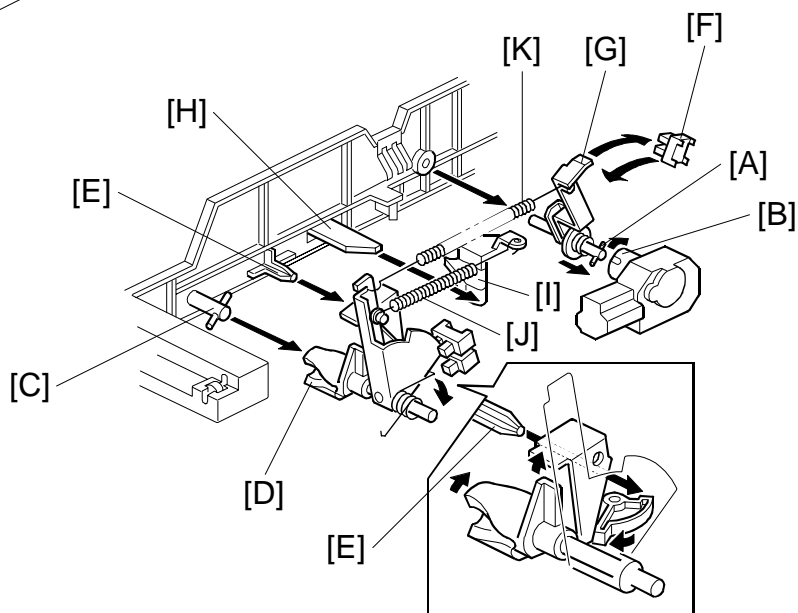

B390D107.WMF

The paper size switch detects when the tray is pushed in.

When the paper tray is pushed into the machine, the pin [A] for the lift motor pressure shaft engages the lift motor coupling [B] and the pin [C] for the bottom plate lift shaft in the tray engages the bottom plate pressure lever coupling [D]. The pin [E] on the rear of the tray pushes the lock lever so that the lift motor can lift the bottom plate pressure lever.

The lift motor turns on, and turns clockwise as viewed on the diagram. The main pressure spring [K] pulls the bottom plate pressure lever, and this lifts the tray bottom plate.

When the top of the stack touches the feed roller, the motor cannot pull up the plate any more, so it pulls the actuator [G] into the lift sensor [F].

The pressure of the feed roller on the paper is now too high, so the lift motor reverses to reduce this pressure. It reverses for 300 ms or 600 ms, depending on the paper size. For smaller paper, it reverses the larger amount (600 ms) to reduce the pressure more.

The paper size thresholds for this feature depend on SP1-908-8, 9, 17, and 18. (Note that there are two paper size thresholds for each tray: small and middle. Some models only use the small threshold.) The amount of reverse depends on SP 1-908-1, 2, 3, 10, 11, and 12. (See the table later in this section for details of how these SP modes work.)

For A4-width paper or wider, a projection [H] on the side fence engages the secondary pressure spring [J] through a lever [I]. Then, the secondary pressure spring [J] applies paper feed pressure in addition to the main pressure spring [K], to ensure that extra pressure is applied to wider paper.

As stated earlier, various SP modes control this mechanism. The following table summarizes them.

No Middle Size Programmed (Default for A250)	With Middle Size Programmed
<p>Paper width: Tray 1: More than 1-908-8 Tray 2: More than 1-908-17 (Default: Wider than HLT)</p> <p>Amount of reverse: Tray 1: 1-908-1 Tray 2: 1-908-10 (Default 300 ms)</p>	<p>Paper width: Tray 1: More than 1-908-9 Tray 2: More than 1-908-18</p> <p>Amount of reverse: Tray 1: 1-908-1 Tray 2: 1-908-10</p>
<p>Paper width: Tray 1: 1-908-8 or less Tray 2: 1-908-17 or less (Default: HLT or narrower)</p> <p>Amount of reverse: Tray 1: 1-908-2 Tray 2: 1-908-11 (Default: 600 ms)</p>	<p>Paper width: Tray 1: More than 1-908-8, up to and including 1-908-9 Tray 2: More than 1-908-17, up to and including 1-908-18</p> <p>Amount of reverse: Tray 1: 1-908-3 Tray 2: 1-908-12</p>
	<p>Paper width: Tray 1: 1-908-8 or less Tray 2: 1-908-17 or less</p> <p>Amount of reverse: Tray 1: 1-908-2 Tray 2: 1-908-11</p>

When the paper tray is pulled out, the pins [A, C] disengage from the couplings [B, D], and the bottom plate drops. To make it easier to push the tray in, the lift motor rotates backwards 1.7 seconds to return the bottom plate pressure lever coupling [D] to the original position.

2.3 PAPER END DETECTION

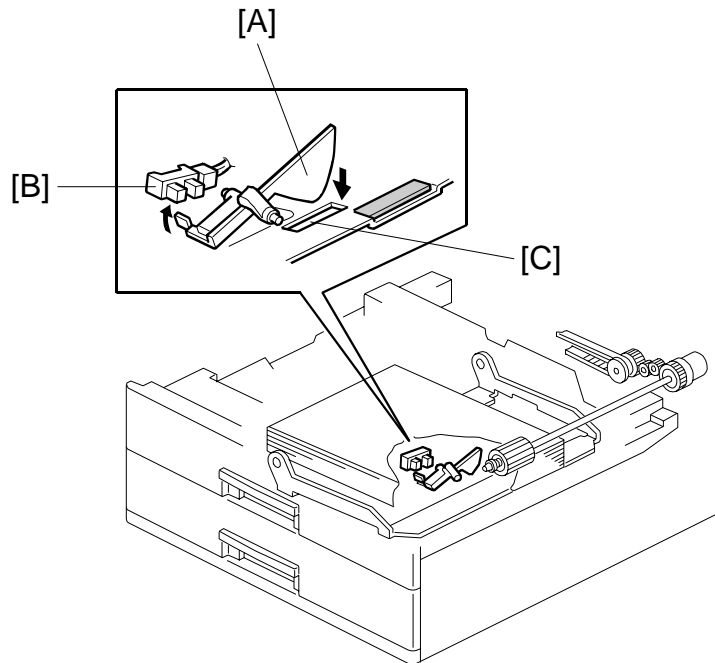

B390D105.WMF

If there is some paper in the paper tray, the paper stack raises the paper end feeler [A] and the paper end sensor [B] is deactivated.

When the paper tray runs out of paper, the paper end feeler drops into the cutout [C] in the tray bottom plate and the paper end sensor is activated.

When the paper tray is drawn out with no paper in the tray, the shape of the paper end feeler causes it to lift up.

2.4 PAPER HEIGHT DETECTION

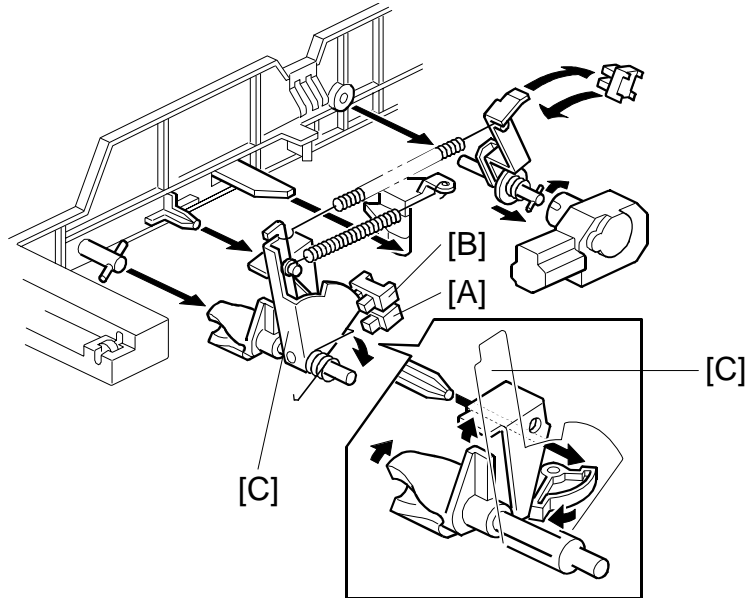

B390D107.WMF

The amount of paper in the tray is detected by the combination of on/off signals from two paper height sensors [A] and [B].

When the amount of paper decreases, the bottom plate pressure lever [C] moves the actuator up.

The following combination of sensor signals is sent to the copier/printer.

Amount of Paper	Paper Height Sensor 1	Paper Height Sensor 2
Near End	OFF	ON
30%	ON	ON
70%	ON	OFF
100%	OFF	OFF

When the tray contains paper of a small width, the paper feed pressure may become too low when the thickness of the remaining stack of paper has decreased. The lift motor rotates forward 300 ms after the sensor detects a certain amount of paper remaining in the tray to increase paper feed pressure, simulating the pressure generated by a full tray.

The amount of remaining paper depends on SP modes 1-908-6, 7, 15, and 16. The amount of forward rotation depends on SP1-908-4, 5, 13, and 14. Note that there are two paper size thresholds for each tray: small and middle (this is the same as for the paper lift mechanism described earlier). Some models only use the small threshold. The paper size thresholds depend on SP1-908-8, 9, 17, and 18.

The following table summarizes how these SP modes work.

No Middle Size Programmed (Default for A250)	With Middle Size Programmed
<p>Paper width: Tray 1: More than 1-908-8 Tray 2: More than 1-908-17 (Default: Wider than HLT)</p> <p>Amount of forward rotation: None</p>	<p>Paper width: Tray 1: More than 1-908-9 Tray 2: More than 1-908-18</p> <p>Amount of forward rotation: None</p>
<p>Paper width: Tray 1: 1-908-8 or less Tray 2: 1-908-17 or less (Default: HLT or narrower)</p> <p>Amount of remaining paper: Tray 1: 1-908-6 Tray 2: 1-908-15 (Default: When near-end is detected)</p> <p>Amount of forward rotation: Tray 1: 1-908-4 Tray 2: 1-908-13 (Default: 300 ms)</p>	<p>Paper width: Tray 1: More than 1-908-8, up to and including 1-908-9 Tray 2: More than 1-908-17, up to and including 1-908-18</p> <p>Amount of remaining paper: Tray 1: 1-908-7 Tray 2: 1-908-16</p> <p>Amount of forward rotation: Tray 1: 1-908-5 Tray 2: 1-908-14</p>
	<p>Paper width: Tray 1: 1-908-8 or less Tray 2: 1-908-17 or less</p> <p>Amount of remaining paper: Tray 1: 1-908-6 Tray 2: 1-908-15</p> <p>Amount of forward rotation: Tray 1: 1-908-4 Tray 2: 1-908-13</p>

2.5 PAPER SIZE DETECTION

Size	SW	1	2	3	4
A3, F (8 1/2" x 13")		●	●	●	○
A4 Lengthwise		●	○	●	○
A4 Sideways		●	○	○	○
A5 Sideways, 11" x 17"		●	●	○	○
B4, 8 1/2" x 14"		○	●	○	○
B5 Sideways, 8 1/2" x 11"		○	○	○	○
B5 Lengthwise, 11" x 8 1/2"		○	○	●	○
* (Asterisk)		○	○	●	●

●: ON (Not pushed)
○: OFF (Pushed)

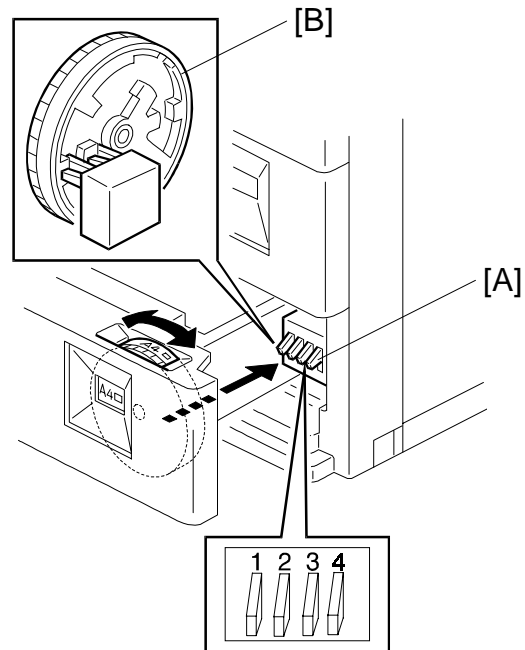

B390D108.WMF

There are four paper size microswitches [A] on the front right plate of the paper tray unit. The switches are actuated by a paper size actuator [B] behind the paper size indicator plate, which is on the front right of the tray.

Each paper size has its own actuator, with a unique combination of notches. To determine which size has been installed, the CPU reads which microswitches the actuator has switched off.

The CPU disables paper feed from a tray if the paper size cannot be detected. If the paper size actuator is broken, or if there is no tray installed, the Add Paper indicator will light.

When the paper size actuator is at the "*" mark, the paper tray can be set up to accommodate one of a wider range of paper sizes by using user tools. If the paper size for this position is changed without changing the user tool setting, a paper jam will result.

2.6 SIDE AND END FENCES

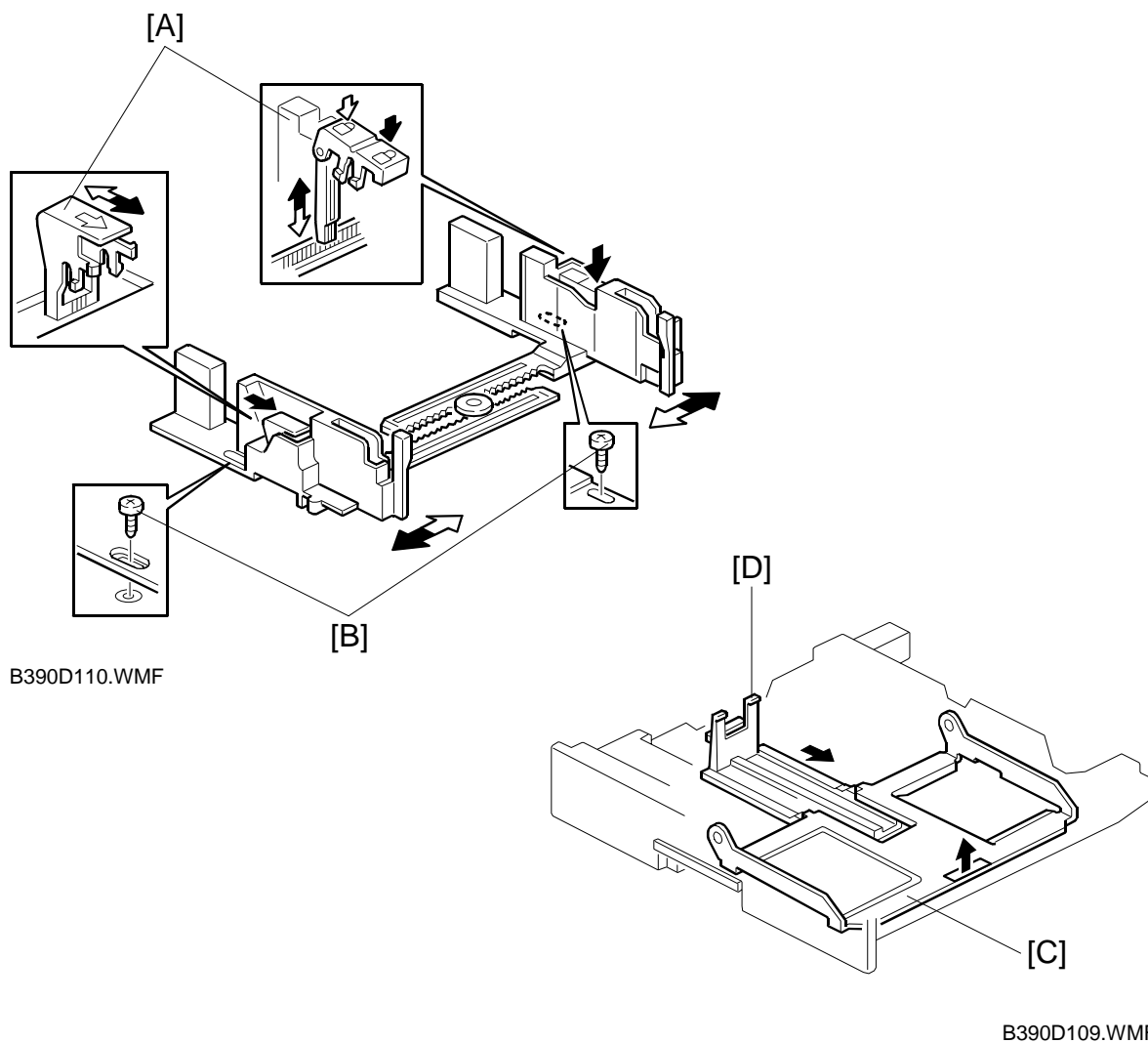

Side Fences

If the tray is full of paper and it is pushed in strongly, the fences may deform or bend. This may cause the paper to skew or the side-to-side registration to be incorrect. To correct this, each side fence has a stopper [A] attached to it. Each side fence can be secured with a screw [B], for customers who do not want to change the paper size.

End Fence

As the amount of paper in the tray decreases, the bottom plate [C] lifts up gradually. The end fence [D] is connected to the bottom plate. When the tray bottom plate rises, the end fence moves forward and pushes the back of the paper stack to keep it squared up.

3. REPLACEMENT AND ADJUSTMENT

3.1 FEED ROLLER REPLACEMENT

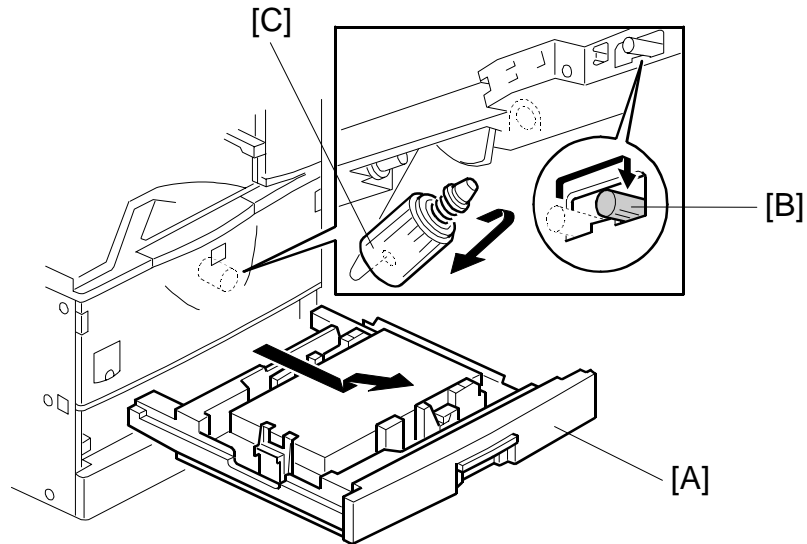

B390R723.WMF

1. Remove the paper tray [A].
2. Move the release lever [B] to the front.
3. Pull the feed roller [C] to the operation side and remove it.
4. Replace the feed roller.

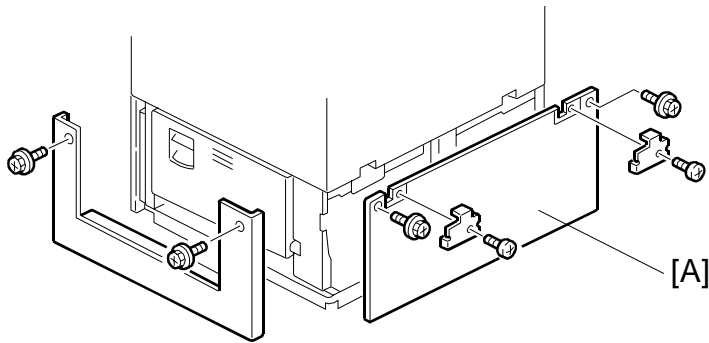

B390R101.WMF

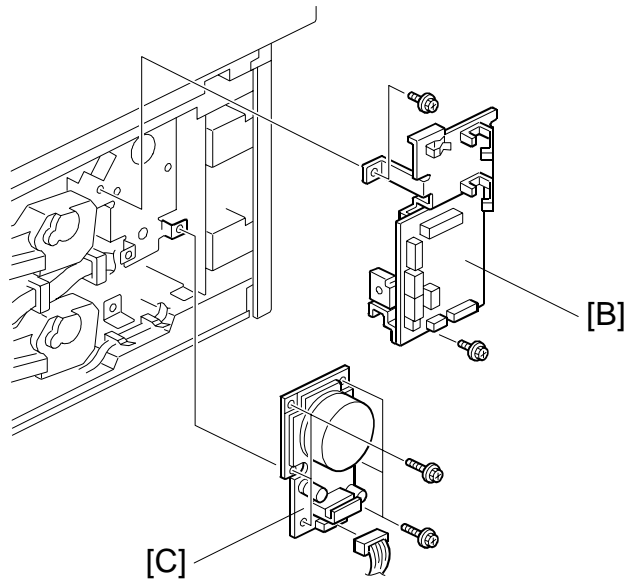

B390R103.WMF

3.2 TRAY MAIN BOARD REPLACEMENT

1. Remove the rear cover [A] (4 screws).
2. Replace the tray main board [B] (4 screws and 8 connectors).

3.3 TRAY MOTOR REPLACEMENT

1. Remove the rear cover (4 screws).
2. Disconnect 8 connectors from the tray main board [B].
3. Remove the tray main board with the bracket (2 screws).
4. Remove the tray motor [C] (6 screws and 1 connector).

3.4 RELAY CLUTCH REPLACEMENT

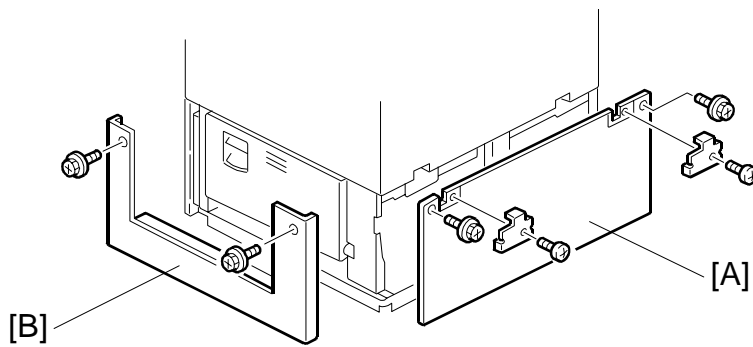

B390R101.WMF

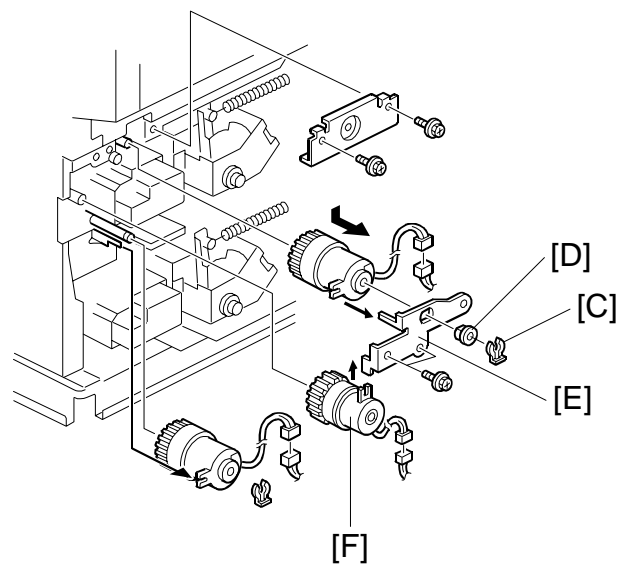

B390R102.WMF

1. Remove the rear cover [A] (4 screws).
2. Remove the right cover [B] (2 screws).
3. Remove the snap ring [C].
4. Remove the bushing [D].
5. Remove the stopper bracket [E] (2 screws).
6. Replace the relay clutch [F] (1 connector).

3.5 UPPER PAPER FEED CLUTCH REPLACEMENT

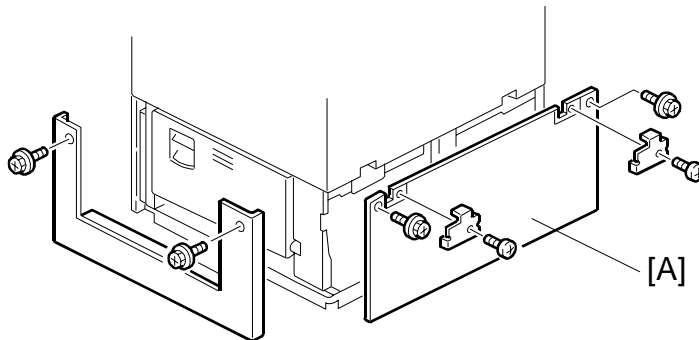

B390R101.WMF

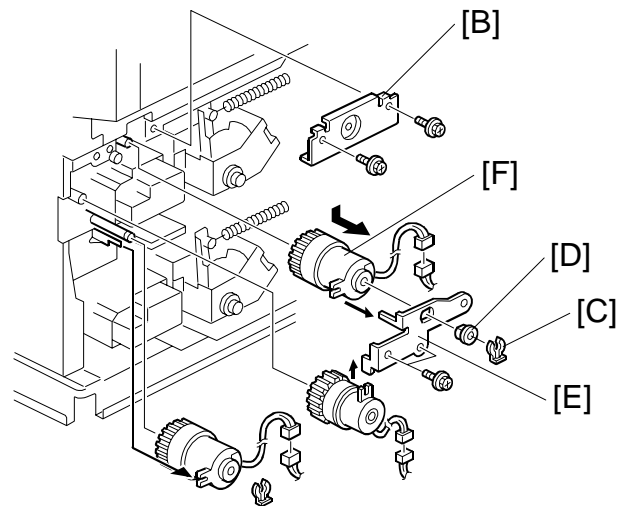

B390R102.WMF

1. Remove the rear cover [A] (4 screws).
2. Remove the bracket [B] (2 screws).
3. Remove the snap ring [C].
4. Remove the bushing [D].
5. Remove the stopper bracket [E] (2 screws).
6. Replace the upper paper feed clutch [F] (1 connector).

3.6 LOWER PAPER FEED CLUTCH REPLACEMENT

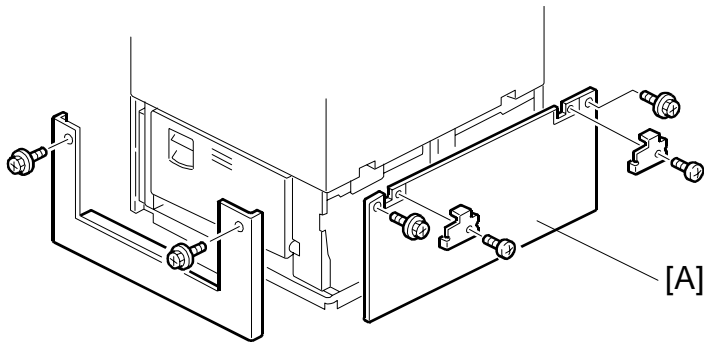

B390R101.WMF

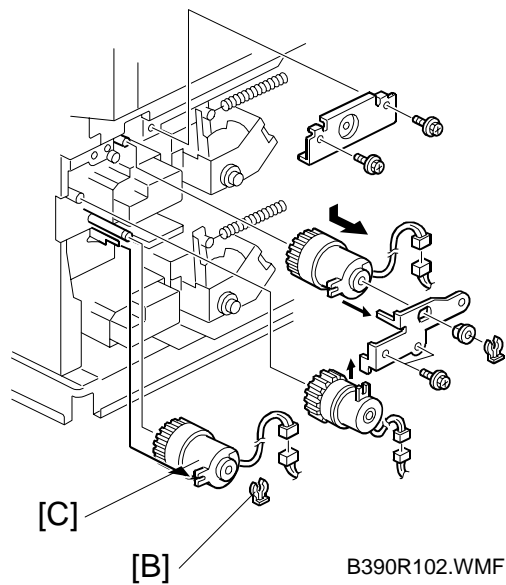

B390R102.WMF

1. Remove the rear cover [A] (4 screws).
2. Remove the snap ring [B].
3. Replace the lower paper feed clutch [C].

3.7 LIFT MOTOR REPLACEMENT

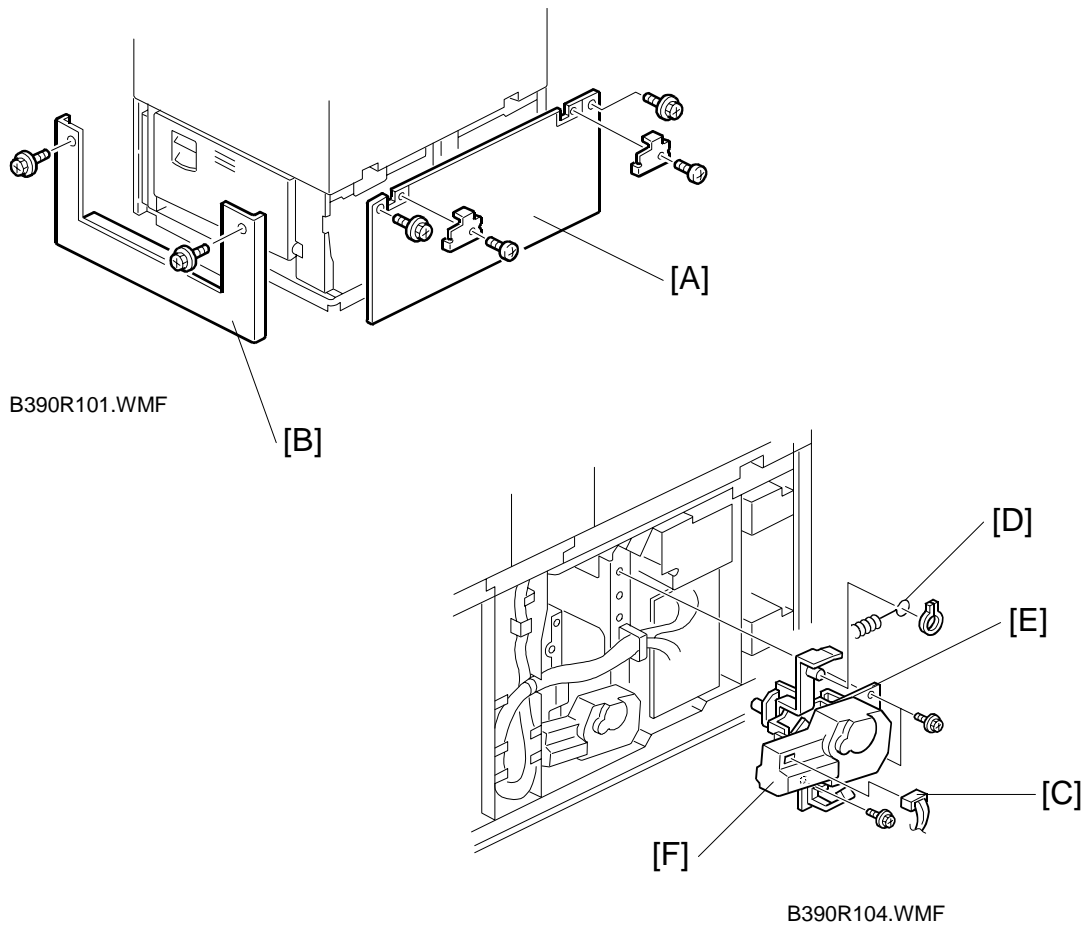

1. Pull out the paper tray.
2. Remove the rear cover [A] (4 screws) and the bracket [B] (2 screws).
3. Disconnect the 2P connector [C].
4. Remove the spring [D].
5. Remove the lift motor unit [E] (3 screws).
6. Remove the lift motor [F] (2 screws).

3.8 PAPER END SENSOR REPLACEMENT

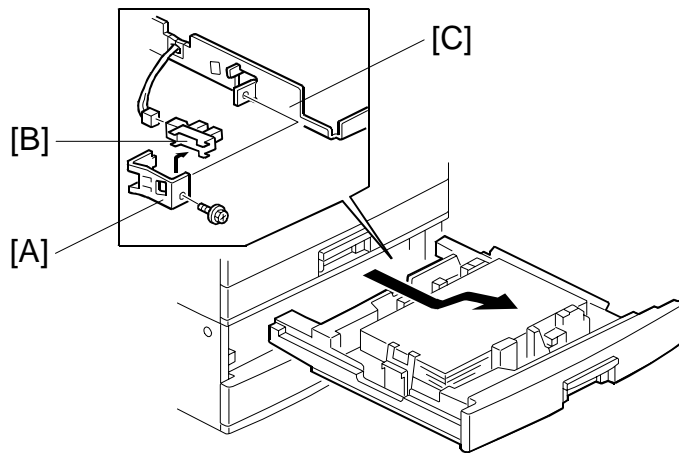

B390R106.WMF

1. Remove the paper tray.
2. Remove the paper end sensor bracket [A] (1 screw and 1 connector).
3. Replace the paper end sensor [B].

NOTE: After replacing the sensor, pull the sensor cable towards the right side of the frame [C] so that it does not touch the paper in the tray.

3.9 VERTICAL TRANSPORT SENSOR REPLACEMENT

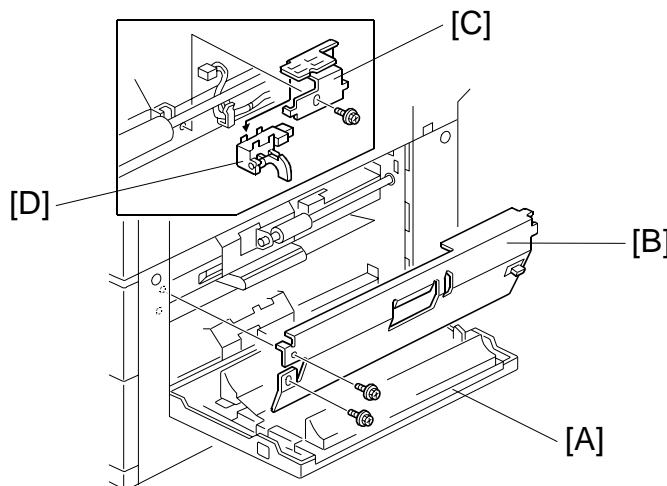

B390R105.WMF

1. Open the right door [A].
2. Remove the right guide plate [B] (2 screws).
3. Remove the vertical transport sensor bracket [C] (1 screw and 1 connector).
4. Replace the vertical transport sensor [D].

3.10 PAPER SIZE SWITCH REPLACEMENT

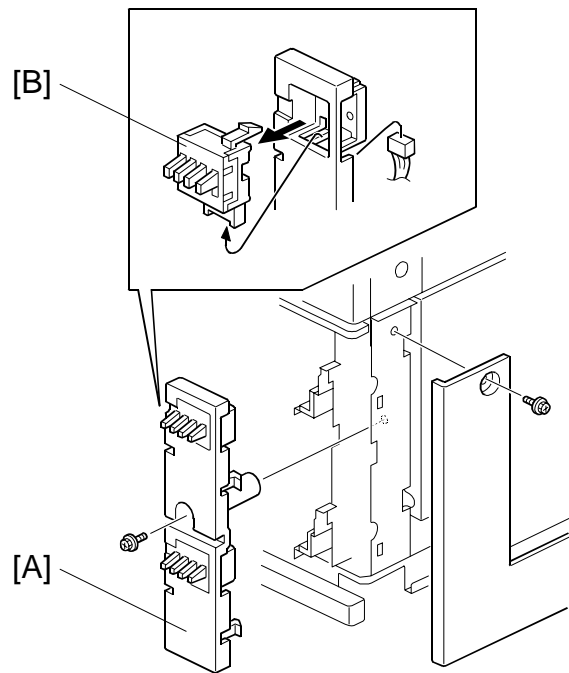

B390R108.WMF

1. Remove the upper and lower paper trays.
2. Remove the inner cover [A] (2 screws).
3. Replace the paper size switch [B] (1 connector).